



IFZ800

Fully Integrated Freezer

INSTALLATION AND USER INSTRUCTIONS

**You must read these instructions prior to using the
appliance and retain them for future reference.**

Contents

Introduction & safety warnings.....	2
Electrical requirements	3
Transportation instructions.....	4
Installation instructions.....	5
Repositioning the door	6
Starting.....	8
Temperature control and adjustment	9
Storing frozen food.....	9
Freezing fresh food	10
Defrosting.....	11
Cleaning and care.....	12
Do's and don'ts	13
Problem solving	13
Installation instructions - detailed step by step	14
Guarantee details.....	20
How to obtain service.....	21
Technical data	22
Wiring diagram.....	23
Customer Care.....	back cover

Please keep this handbook for future reference, or for anyone else who may use the appliance.

Congratulations on your choice of a Belling quality Appliance which has been designed to give you service for many years.

**WARNING !
IMPORTANT !**

DO NOT connect your appliance to the electricity supply until all packing and transit protectors have been removed.

- Leave to stand for at least 4 hours before switching on to allow compressor oil to settle if transported horizontally.
 - If you are discarding an old refrigerator with a lock or latch fitted to the door, disable the lock/latch, ensure that it is left in a safe condition to prevent the entrapment of young children.
 - This freezer must only be used for its intended purpose i.e the storing and freezing of edible foodstuff.
 - Do not dispose of the appliance on a fire. At Belling, the care and protection of our environment is an ongoing commitment. This appliance which is among the latest range introduced is particularly environment friendly. Your appliance contains non CFC / HFC natural substances in the cooling system (Called R600a) and in the insulation (Called cyclopentane) which are potentially flammable if exposed to fire. Therefore, take care not to damage, the cooling circuit / pipes of the appliance in transportation and in use. In case of a damage do not expose the appliance to fire, potential ignition source and immediately ventilate the room where the appliance is situated.
 - We suggest you contact your local authority for disposal information and facilities available.
 - You may install your freezer in an unheated cold room (E.g.: garage, conservatory, annex) provided it is protected from rain, moisture, excessive heat.
 - To obtain the best possible performance and trouble free operation from your appliance it is very important to carefully read these instructions.
 - On delivery, check to make sure that the product is not damaged and that all the parts and accessories are in perfect condition.
 - Ensure that the plug remains readily accessible. Do not use a multiple adapter bar or extension cable.
 - Failure to observe these instructions may invalidate your right to free service during the guarantee period.
- WARNING-** Keep ventilation openings, in the appliance enclosure or in the built-in structure, clear of obstruction.
- WARNING-** Do not use mechanical devices or other means to accelerate the defrosting process, other than those recommended by the manufacturer.
- WARNING-** Do not damage the refrigerant circuit.
- WARNING-** Do not use electrical appliances inside the food storage compartments of the appliance, unless they are of the type recommended by the manufacturer.
- We suggest you keep these instructions in a safe place for easy reference.

ELECTRICAL REQUIREMENTS

Before you insert the plug into the wall socket make sure that the voltage and the frequency shown in the rating plate inside the appliance corresponds to your electricity supply. Rating label is on the left hand side of freezer inner liner. We recommend that this appliance is connected to the mains supply via a suitable switched and fused socket in a readily accessible position. Should the mains lead of the appliance become damaged or should it need replacing at any time, it must be replaced by a special purpose made mains lead which can only be obtained from a Belling Authorised Service Agent.

WARNING! THIS APPLIANCE MUST BE EARTHED

If the fitted moulded plug is not suitable for your socket, then the plug should be cut off and an appropriate plug fitted. Destroy the old plug which is cut off as a plug with bared cord could cause a shock hazard if inserted into a socket elsewhere in the house.

The moulded plug on this appliance incorporates a 13 A fuse. Should the fuse need to be replaced an ASTABEAB approved BS 1362 fuse of the same rating must be used. Do not forget to refit the fuse cover. In the event of losing the fuse cover the plug must not be used until a replacement fuse cover has been fitted. Colour of the replacement fuse cover must be the same colour as that visible on the pin face of the plug. Fuse covers are available from any good electrical store.

IMPORTANT! FITTING A DIFFERENT PLUG

As the colours of the wires in themains lead of this appliance may not correspond with the colouredmarkings identifying the terminals in your plug proceed as follows: (See diagram).

1. Connect the green-yellow or green (Earth) wire to the terminal in the plug marked 'E' or with the

symbol  or coloured green and yellow or green.

2. Connect the blue (Neutral) wire to the terminal in the plug marked 'N' or coloured black.

3. Connect the brown (Live) wire to the terminal in the plug marked 'L' or coloured red. With alternative plugs a 13 A fuse must be fitted either in the plug or adaptor or in the main fuse box.

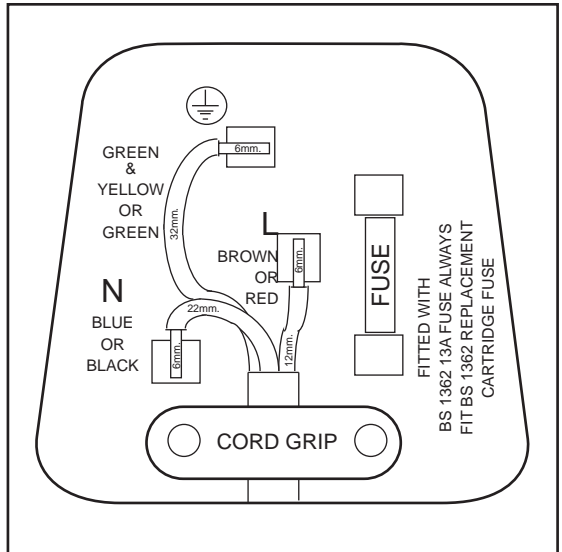

If in doubt contact a qualified electrician.

TRANSPORTATION INSTRUCTIONS

1. The appliance should be transported only in a vertical upright position. The packing as supplied must be intact during transportation.
2. If during the course of transport the appliance has to be transported horizontally, it must only be laid on its left hand side when standing in the front of the appliance. After bringing it to upright position, it must not be operated for at least 4 hours to allow the system to settle.
3. Failure to comply with the above instructions could result in damage occurring to the appliance. The manufacturer will not be held responsible if these instructions are disregarded.
4. The appliance must be protected against rain, moisture and other atmospheric influences.
5. When positioning your appliance take care not to damage your flooring, pipes, wall coverings etc. Do not move the appliance by pulling by the door or handle.

IMPORTANT : Care must be taken while cleaning / carrying the appliance to avoid touching the bottom of the condenser metal support or pipework at the back of the appliance as you might injure your fingers and hands or damage your product.

IMPORTANT : This appliance is not designed for stacking with any other appliance.

Do not attempt to sit or stand on top of your appliance as it is not designed for such use. You could injure yourself or damage the appliance.

IMPORTANT : Make sure that mains cable is not caught under the appliance during and after carrying / moving the appliance, to avoid the mains cable becoming cut or damaged.

Do not allow children to play with the appliance or tamper with the controls.

Take care when installing your appliance and using it for the first time, during normal daily use, while defrosting and cleaning the interior freezer compartments not to damage cold panels and pipes and to avoid any injury. We recommend the use of a pair of gloves when cleaning the cold panels as you might injure your fingers and hands and/or damage the appliance beyond repair.

Belling declines to accept any liability should the instructions not be followed.

IMPORTANT INSTALLATION INSTRUCTIONS

1. To avoid a hazard due to instability of the appliance, it must be fixed in accordance with the instructions.
2. Do not operate this appliance unless installed to furniture.
3. The appliance should be located on a smooth surface. The four front and back feet can be adjusted as required. To ensure that, your appliance is standing upright adjust the four front and back feet by turning clockwise or anti-clockwise, until the product is in firm contact with the floor. Correct adjustment of feet avoids excessive vibration and noise.
4. Refer to "Cleaning and Care" section to prepare your appliance for use.

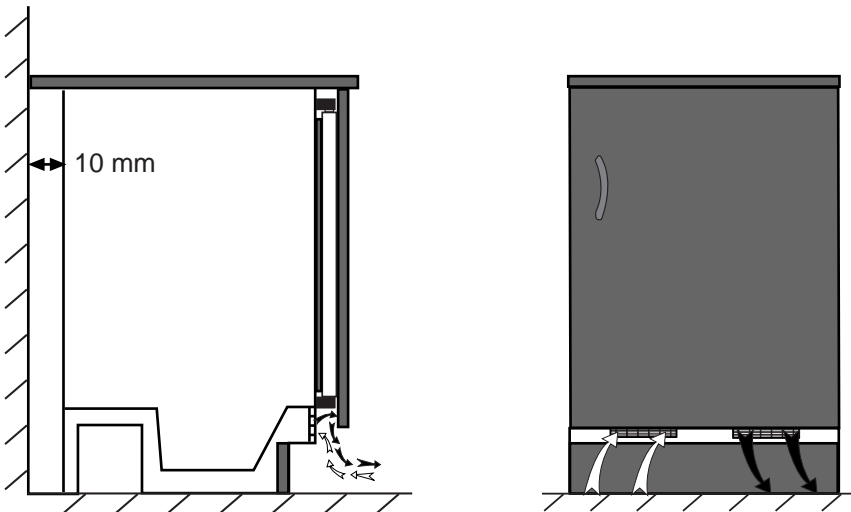

To avoid any loss in performance, air suction channels should not be obstructed. (140 cm²)

Minimum distance between the wall and the appliance must be at least 10 mm.

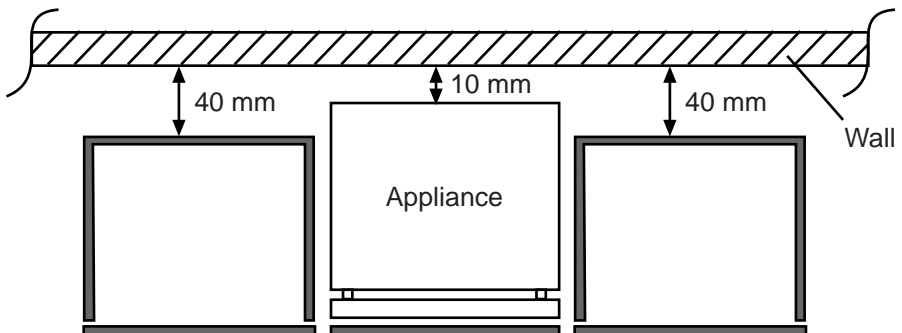

REPOSITIONING THE DOOR

Follow the step by step instructions and the diagram below. Numbers in brackets refer to diagrams.

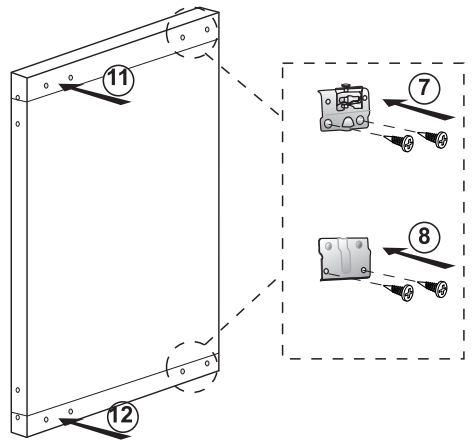
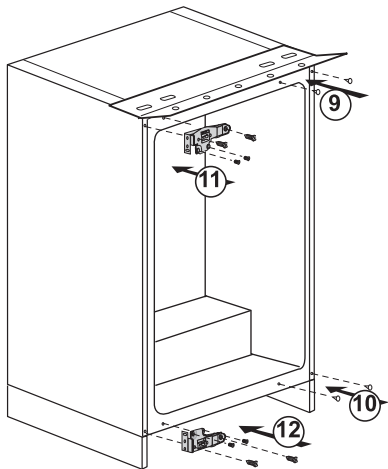
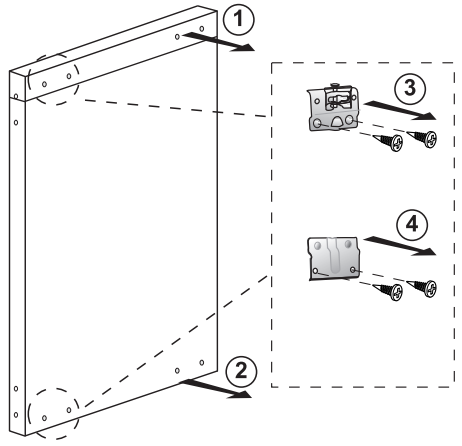
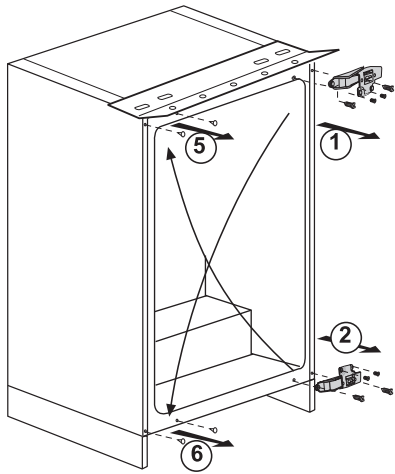

1. Switch off at the socket outlet and pull out the mains plug.
2. Remove all food, loose items and fittings from inside the appliance and door shelves.
3. Unscrew the bolts and remove the upper and bottom hinges from the cabinet and door. (1) (2)
4. Remove stoppers. (3) (4)
5. Fit the stoppers on the opposite side. (5) (6)
6. Reposition the upper hinge on the opposite side as bottom hinge (7)
7. Reposition the bottom hinge on the opposite side as upper hinge. (8) Locate the door and tighten the bolts fixing the door.

STARTING

Final Check

Before you start using the freezer check that:

1. The feet have been adjusted and the product is level.
2. The interior is dry and air can circulate freely at the rear.
3. Clean the interior as recommended under "CLEANING AND CARE."
4. Insert the plug into the wall socket and switch on the electricity supply. Avoid accidental disconnection by taping over the switch.
5. You will hear a noise as the compressor starts up. The liquid and gases sealed within the refrigeration system may also give rise to noise, whether the compressor is running or not which is quite normal.
7. Front edges of the cabinet may feel warm. This is normal. These areas are designed to be warm to avoid condensation.
9. Do not load the appliance immediately it is switched on. Wait until the correct storage temperature has been reached. We recommend that you check the temperature with an accurate thermometer (see; Temperature Control and Adjustment).

Important Notes :

1. If there is a power failure do not open the door. Frozen food should not be affected if the failure lasts for less than 19 hours. If the failure is longer, then the food should be checked and either eaten immediately or cooked and then re-frozen.
2. If you find the freezer door difficult to open just after you have closed it, don't worry. This is due to the pressure difference which will equalise and allow the door to open normally after a few minutes.
3. Always wrap food using a suitable packaging material before storing in your appliance to avoid contact with the appliance surface and food remains for hygiene reasons.
4. The appliance may go to OFF position when the knob is adjusted below MIN. When the green indicator light is OFF, the appliance is turned OFF also.

Once it is turned OFF (even for defrosting), please adjust the knob somewhere above MIN to be sure that it is turned ON again. When the appliance is turned ON, the green indicator will light up.

TEMPERATURE CONTROL AND ADJUSTMENT

There are three coloured indicator lights located inside the appliance which show the operating mode of the freezer.

Green Indicator (1)

Illuminates when the appliance is connected to the mains and will glow as long as there is electricity present. The green light will not glow if the thermostat is set in the 'O' position. The green indicator does not give any indication of the temperature inside the freezer.

Amber Indicator (2)

This indicator will glow when the **fast-freeze switch (4)** is on and will continue to glow until the fast-freeze switch is turned off. The compressor will run continuously whilst the fast-freeze switch is on. Fast-freeze operation is for freezing fresh food (see Freezing Fresh Food, section).

Red Indicator (3) Illuminates:

- a. If the pre-set temperature can not be maintained.
- b. If the appliance is overloaded with fresh food.
- c. If the appliance door is left open accidentally.

Thermostat knob (5)

The thermostat knob is located on the indicator light frame.

Important:

When you press the fast-freeze switch, there may be a short delay before the compressor starts to operate. This is normal and not a compressor fault.

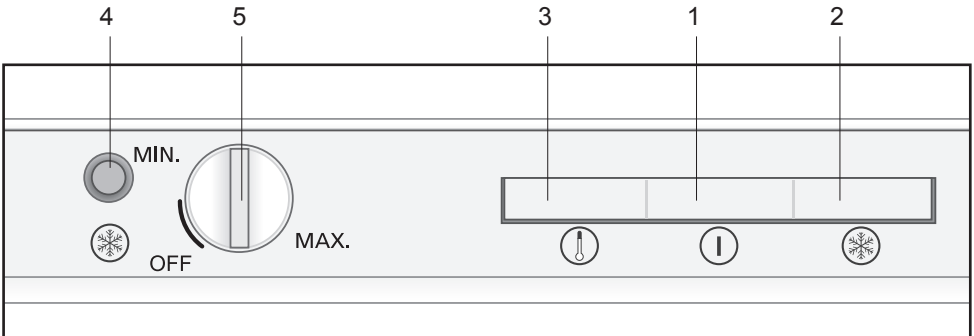

STORING FROZEN FOOD

Prepacked commercially frozen food should be stored in accordance with the frozen food manufacturer's instructions for a ❄️ frozen food storage compartment.

The freezing area is marked with ❄️ symbol on the door liner.

To ensure that the high quality achieved by the frozen food manufacturer and the food retailer is maintained the following should be remembered:

1. Put packets in the freezer as quickly as possible after purchase.
2. Do not exceed "Use By", "Best Before" dates on the packaging.
3. Please note that drawers, baskets, flaps, trays are all removable.

FREEZING FRESH FOOD

Freezing capacity of your appliance in a 24 hours period is 10 kg (22.1 lb).

Never exceed this maximum capacity. Fast freeze compartment (3) is shown in diagram.

Take special care not to mix already frozen food and fresh food. If the fast freeze compartment (3) is filled with fresh food, other compartments can also be used to freeze fresh food.

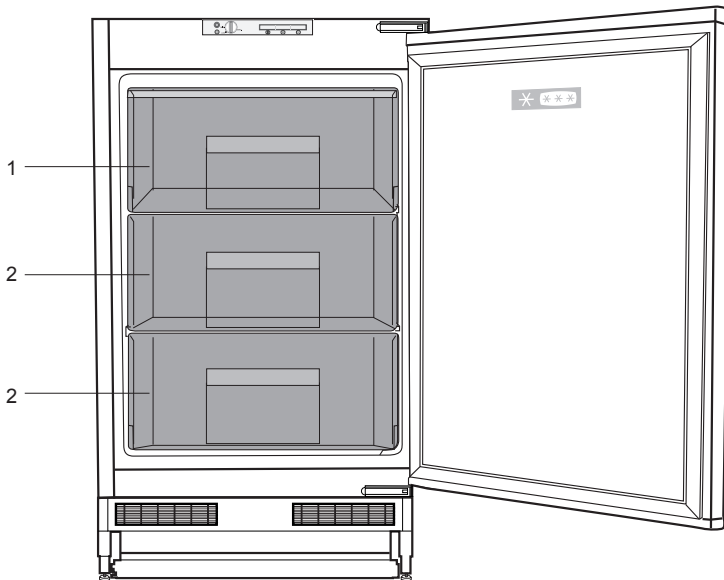

1. Fast-freeze compartment
2. Frozen-food compartments

DEFROSTING

Defrost twice a year or when a frost layer of around 7 mm (1/4") has formed. To start defrosting procedure turn the thermostat knob to zero position (Alternatively you may switch off the freezer at the socket outlet and pull out the mains plug.)

All food should be wrapped in several layers of newspaper and stored in a cool place (e.g. fridge or larder).

Remove all freezer drawers. The special defrost collection basin collects the defrost water. Therefore defrosting can be conducted without mess.

Containers full of warm water may be placed carefully in the freezer to speed up the defrosting.

Do not use pointed or sharp edged objects such as knives, forks to remove the frost.

Never use hairdryers, electrical heaters and other similar electrical appliances for defrosting.

When defrosting has finished, sponge out any defrost water which collects at the bottom of the freezer and dry the interior thoroughly. Turn the thermostat knob to mid point. Close the freezer door. Insert the plug into the wall socket and switch on the electricity supply. Don't forget to tape over the switch to avoid accidental disconnection.

CLEANING AND CARE

- ** We recommend that you switch off the freezer at the socket outlet and pull out the mains plug before cleaning.
- ** Never use any sharp abrasive instrument, soap, household cleaner, detergent and wax polish for cleaning.
- ** Use luke warm water to clean the cabinet of the freezer and wipe it dry.
- ** Use a damp cloth wrung out in a solution of one teaspoon of bicarbonate of soda to one pint of water to clean the interior and wipe it dry.
- ** Excess deposit of ice should be removed on a regular basis using the handle of a spoon. Large accumulation of ice will impair the performance of the freezer.
- ** If the freezer is not going to be used for a long period of time switch it off, remove all food, clean it and leave the door ajar.
- ** To remove a drawer, pull it as far as possible, and then tilt it upwards, and then pull it out completely.
- ** Check door seals regularly to ensure they are clean and free from food particles.
- ** Never :
 - Subject it to hot temperatures in any way,
 - Scour, rub etc., with abrasive material.
- ** Take care when installing your appliance and using it for the first time, during normal daily use, while defrosting and cleaning the interior freezer compartments not to damage cold panels and pipes and to avoid any injury. We recommend the use of a pair of gloves when cleaning the cold panels as you might injure your fingers and hands and/or damage the appliance beyond repair.

DO'S AND DON'TS

- Do- Check contents of the freezer at regular intervals.
- Do- Clean and defrost your freezer regularly (See "Defrosting")
- Do- Keep food for as short a time as possible and adhere to "Best Before", "Use By" dates.
- Do- Store commercially frozen food in accordance with the instructions given on the packets that you buy.
- Do- Always choose high quality fresh food and be sure it is thoroughly clean before you freeze it.
- Do- Prepare fresh food for freezing in small portions to ensure rapid freezing.
- Do- Wrap all foods in aluminium foil or freezer quality polythene bags and make sure any air is excluded.
- Do- Wrap frozen food when you buy it and put it in to the freezer as soon as possible.
- Do- Separate food in the compartments. This will enable you to find food quickly and avoid excessive door opening therefore save electricity.
- Do- Remove ice cream from the freezer 10-20 minutes before serving.
- Don't- Leave the door open for long periods as this will make the freezer more costly to run and cause excessive ice formation.
- Don't- Use pointed sharp edged objects such as knives, forks to remove the ice.
- Don't- Put hot food into the freezer. Let it cool down first.
- Don't- Put liquid-filled bottles or sealed cans containing carbonated liquids into the freezer as they may burst.
- Don't- Store poisonous or dangerous substances in the Freezer. Your freezer has been designed for the storage of edible foodstuffs only.
- Don't- Exceed the maximum freezing capacity (10 kg in any 24 hours) when freezing fresh food.
- Don't- Consume ice-cream and water ices direct from the freezer. The low temperature may cause 'freezer burns' on lips.
- Don't- Freeze fizzy drinks.
- Don't- Try to keep frozen food which has thawed, it should be eaten within 24 hours or cooked and refrozen.
- Don't- Remove items from the freezer with wet hands.
- Don't- Close the door before placing the fast-freeze compartment cover in its place.
- Don't- Leave frozen food at room temperature to thaw; the best way to defrost food is to put it in the fridge to thaw slowly. Make sure you avoid defrosting food or food juices drip onto other food.

PROBLEM SOLVING

If the appliance does not operate when switched on, check:

- The plug is inserted properly in the socket and that the power supply is on. (To check the power supply to the socket, plug in another appliance)
- The fuse has blown/circuit breaker has tripped/main distribution switch has been turned off.
- The temperature control has been set correctly.
- New plug is wired correctly if you have changed the fitted moulded plug.

If the appliance is still not operating after the above checks, please refer to the section on "How To Obtain Service".

Please ensure that above checks have been made as a charge will be made if no fault is found.

INSTALLATION INSTRUCTIONS - DETAILED STEP BY STEP

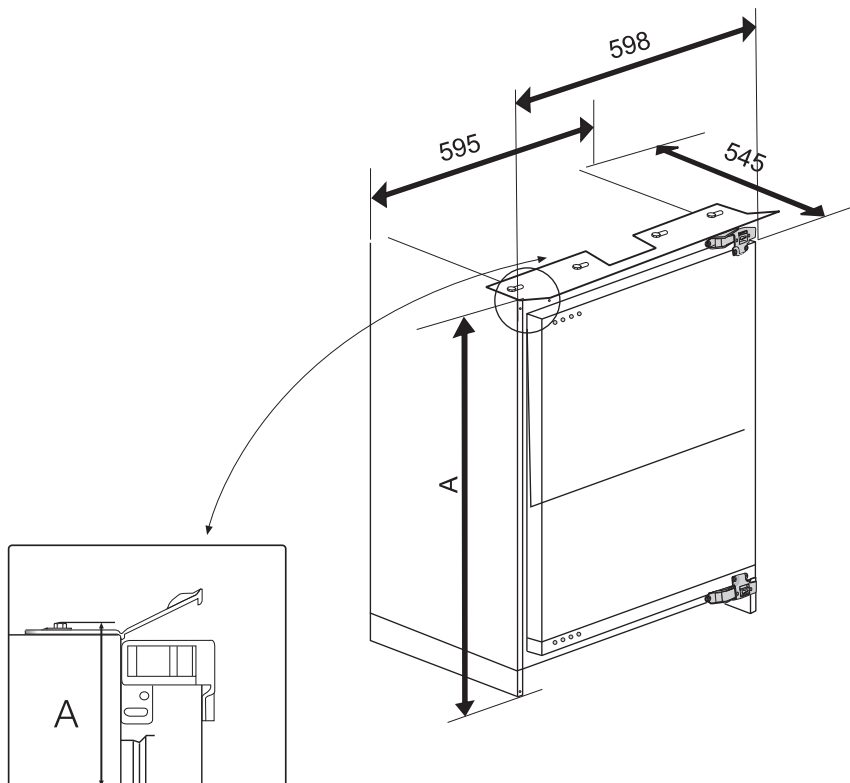

A (mm)	820 - 870 mm
C (mm)	100 - 150 mm

NOTE

- 1) Height of the product can be adjusted by the help of adjustable feet (front and back) to fit the furniture niche height (B).
- 2) Do not operate this appliance until it has been installed in the furniture.

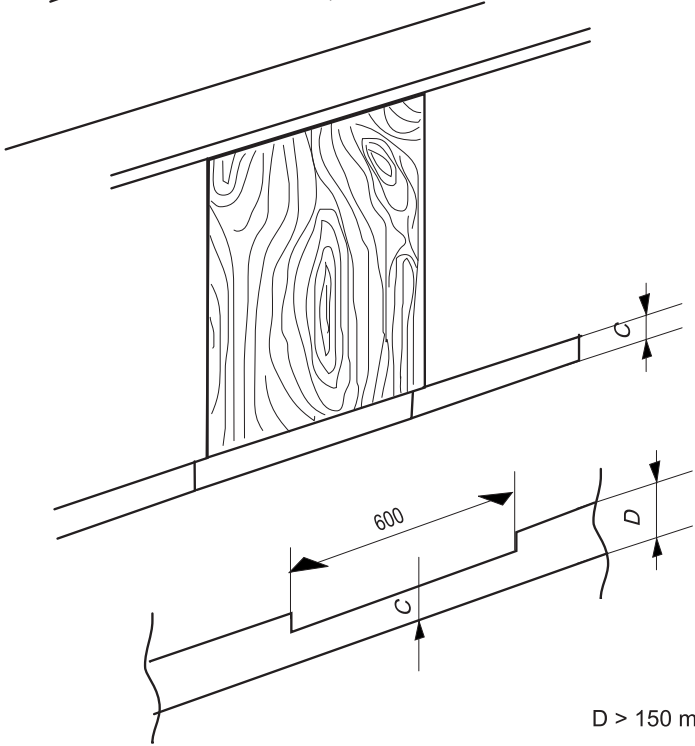
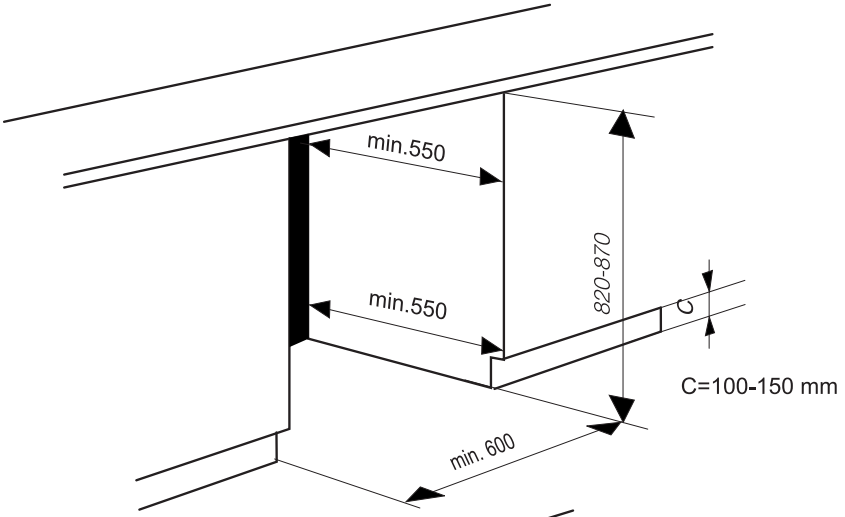

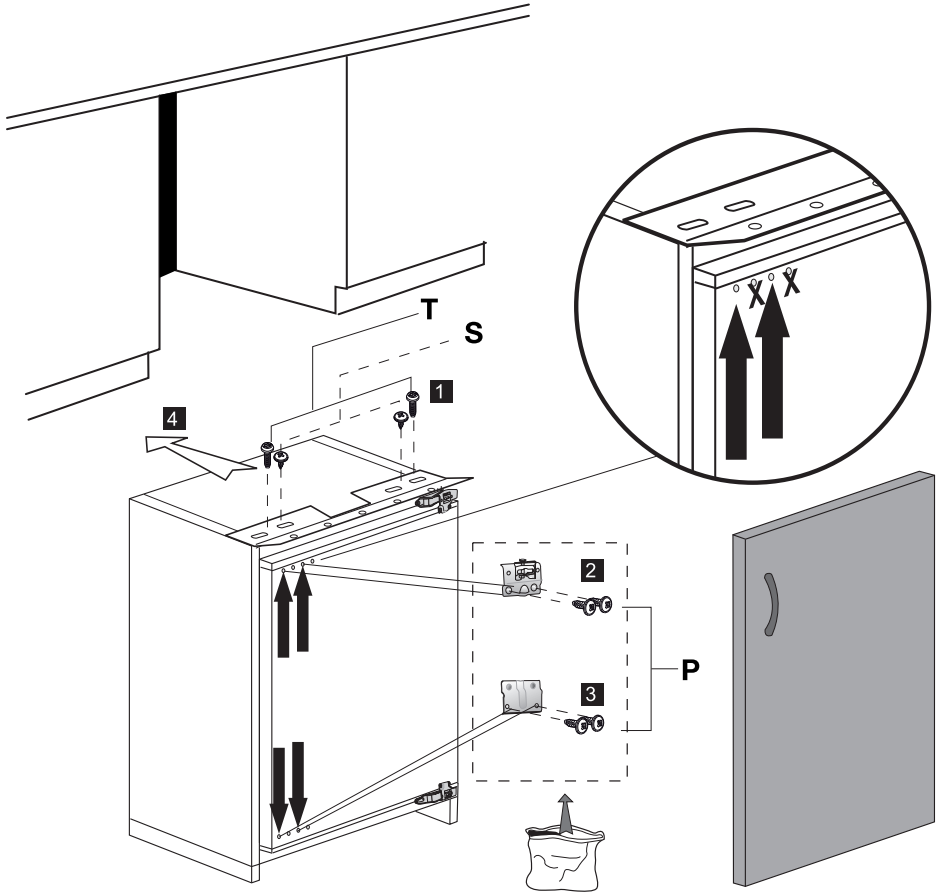
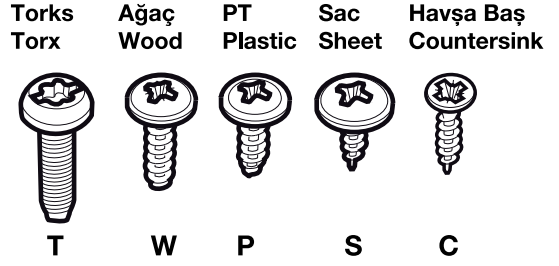

Note: Installation step for 2, screws for connecting top plastic rpart should not be screwed very hard, because of moving the plastic part easily left or right side

E = 3 mm is recommended.

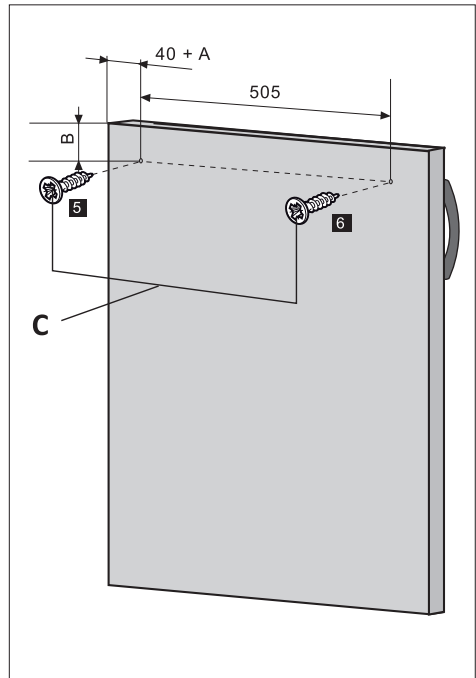
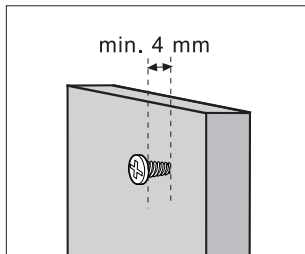
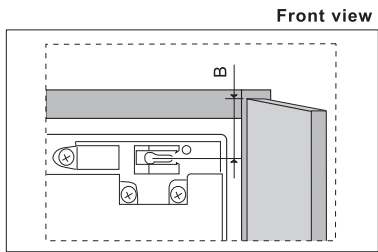
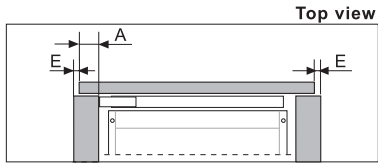

Note:

1. These dimensions are valid for products, which are hinged on right hand side.
2. When door opening direction is reversed, mirror image of this instruction should be considered. That is, dimensions should be considered for opposite sides.

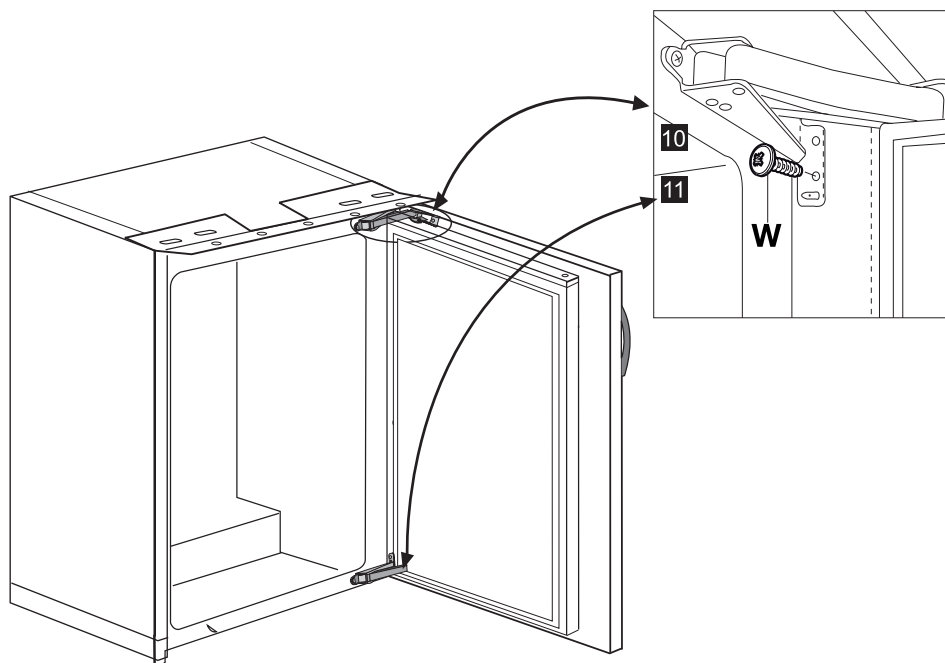
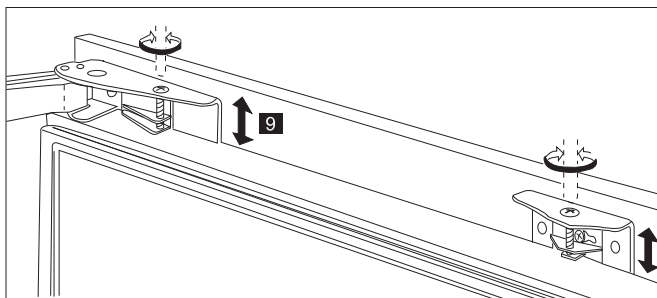
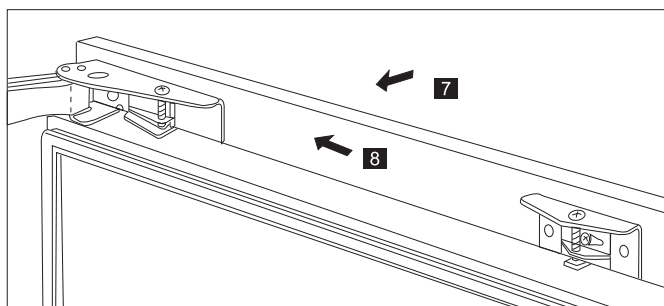

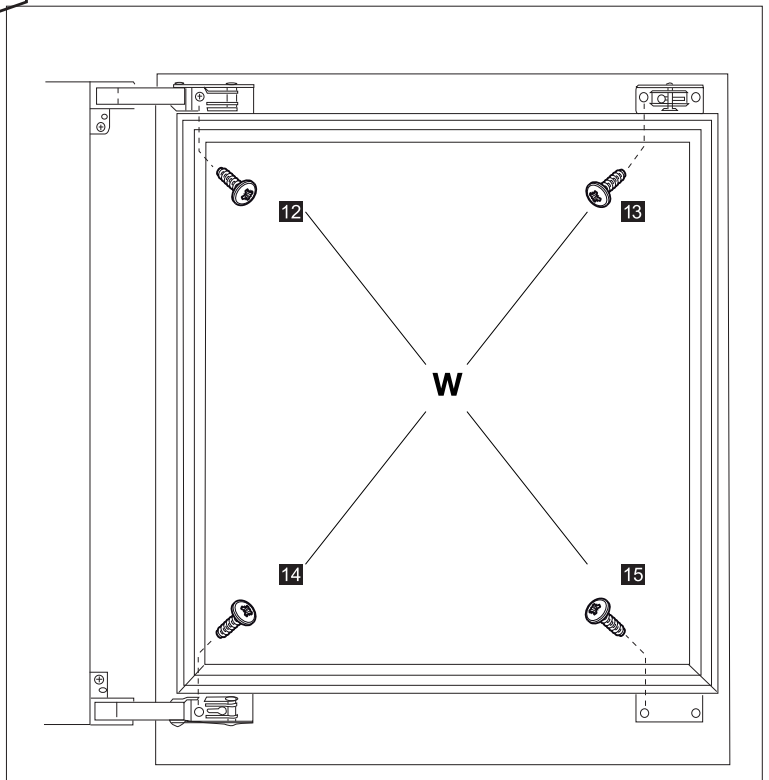
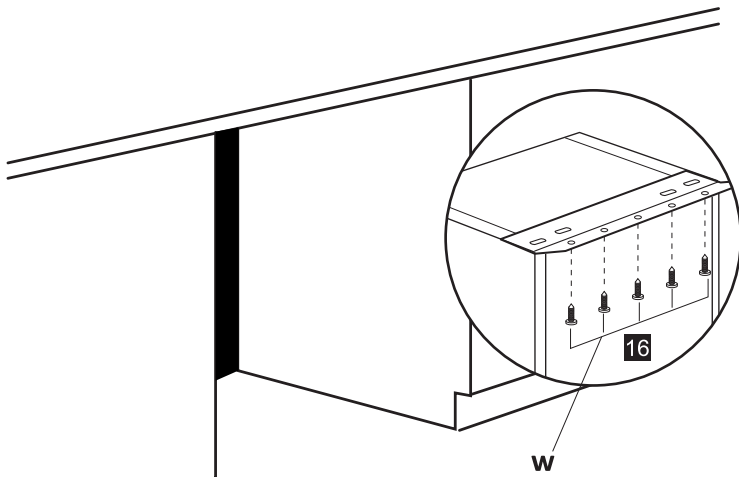

GUARANTEE DETAILS

Your new Belling product is guaranteed against the cost of breakdown repairs for twelve months from the date of the original purchase.

What is covered?

- Repairs necessary as a result of faulty materials, defective components or manufacturing defect.
- The cost of functional replacement parts, but excluding consumable items.
- The labour costs of a Belling approved repairer to carry out the repair.

What is not covered?

- Transit, delivery or accidental damage or misuse and abuse.
- Cabinet or appearance parts, including knobs, flaps, handles or container lids.
- Accessories or consumable items including but not limited to, ice trays, scrapers, cutlery baskets, filters and light bulbs.
- Repairs required as a result of unauthorised repair or inexperienced installation that fails to meet the requirements contained in the user instruction book.
- Repairs to products used on commercial or non-residential household premises.
- Loss of frozen food in freezers or fridge/freezers. (Food loss insurance is often included within your household contents insurance policy, or may be available separately from your retailer).

Important notes.

- Your Belling product is designed and built for domestic household use only.
- The guarantee will be void if the product is installed or used in commercial or non-residential domestic household premises.
- The product must be correctly installed, located and operated in accordance with the instructions contained in the User Instructions Booklet provided.
- The guarantee is given only within the boundaries of the United Kingdom and the Republic of Ireland.
- The guarantee is applicable only to new products and is not transferable if the product is resold.
- Belling disclaims any liability for incidental or consequential damages. The guarantee does not in anyway diminish your statutory or legal rights.

HOW TO OBTAIN SERVICE

Please keep your purchase receipt or other proof of purchase in a safe place; you will need to have it should the product require attention under guarantee.

You should also complete the details below; it will help us assist you when requesting service.

(The model number is printed on the Instruction Booklet and the serial number is printed on the Rating Label affixed to the appliance)

Model No: Serial No: Retailer: Date of purchase:

Before requesting service please check the problem solving section in the Operating Instructions as a charge may be levied where no fault is found even though your product may still be under guarantee.

Service once the manufacturers guarantee has expired.

If you have purchased an extended guarantee please refer to the instructions contained within the extended guarantee agreement document.

Otherwise please call the appropriate number above where service can be obtained at a charge.

	<p>This product bears the selective sorting symbol for waste electrical and electronic equipment (WEEE). This means that this product must be handled pursuant to European Directive 2002/96/EC in order to be recycled or dismantled to minimize its impact on the environment. For further information, please contact your local or regional authorities.</p> <p>Electronic products not included in the selective sorting process are potentially dangerous for the environment and human health due to the presence of hazardous substances.</p>
--	---

Technical data

PERFORMANCE	Fully Integrated Freezer IFZ800
Energy efficiency class	A+
Energy consumption - Kwh/year	191
Net storage - vol fresh food ltrs (cu.ft.)	-----
Net storage - vol frozen food ltrs (cu.ft)	87 (3.1)
Total net vol - ltrs (cu.ft.)	87 (3.1)
Frozen food compartment rating	4 STAR
Conservation time from failure	19 hrs.
Freezing capacity fresh food - kg /24 hrs.	10
Climate class	SN-T
Operating noise level dB(A)	39

WIRING DIAGRAM

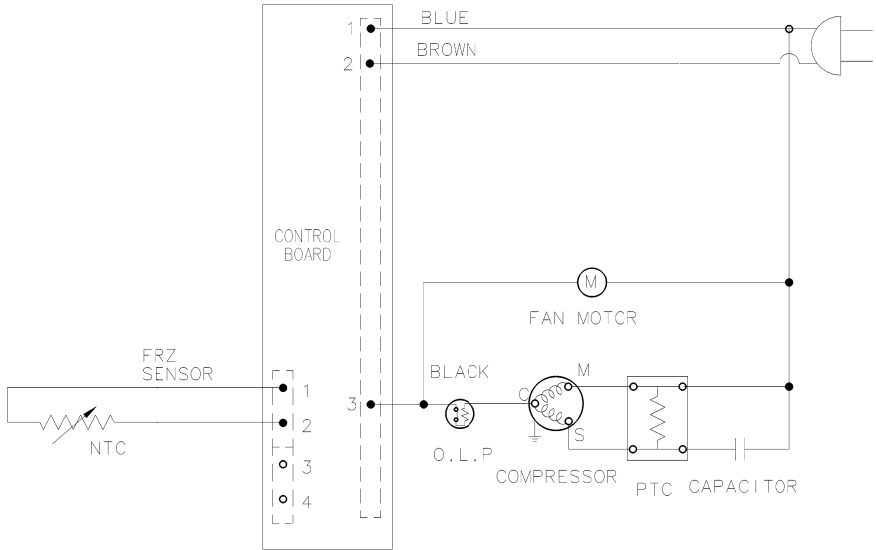

BELLING CUSTOMER CARE

In case of difficulty within the UK, please call
Belling Customer Care Centre Helpline on

0844 815 3746

When you dial this number you will hear a recorded message and be given a number of options.

This indicates that your call has been accepted and is being held in a queue. Calls are answered in strict rotation as our Customer Care Representatives become available.

Enter appliance numbers here for future reference:

Model No							
<input type="text"/>	<input type="text"/>	<input type="text"/>	<input type="text"/>	<input type="text"/>	<input type="text"/>	<input type="text"/>	<input type="text"/>
Serial No							
<input type="text"/>	<input type="text"/>	<input type="text"/>	<input type="text"/>	<input type="text"/>	<input type="text"/>	<input type="text"/>	<input type="text"/>

Please ensure you have the above details (Model No and Serial No) to hand when calling Belling Customer Care. They are essential to booking your call.



Stoney Lane, Prescott, Merseyside, L35 2XW

57 1542 0000 / AB