



Instructions for: **SAC9001** **Air Conditioner / Dehumidifier 9000Btu/hr**

Thank you for purchasing a Sealey product. Manufactured to a high standard, this product will, if used according to these instructions, and properly maintained, give you years of trouble free performance.

IMPORTANT: PLEASE READ THESE INSTRUCTIONS CAREFULLY. NOTE THE SAFE OPERATIONAL REQUIREMENTS, WARNINGS & CAUTIONS. USE THE PRODUCT CORRECTLY AND WITH CARE FOR THE PURPOSE FOR WHICH IT IS INTENDED. FAILURE TO DO SO MAY CAUSE DAMAGE AND/OR PERSONAL INJURY AND WILL INVALIDATE THE WARRANTY. KEEP THESE INSTRUCTIONS SAFE FOR FUTURE USE.

1. SAFETY

1.1. Electrical Safety

- ❑ **WARNING!** It is the user's responsibility to check the following:

Check all electrical equipment and appliances to ensure that they are safe before using. Inspect power supply leads, plugs and all electrical connections for wear and damage. Ensure the risk of electric shock is minimised by the installation of appropriate safety devices. An RCCB (Residual Current Circuit Breaker) should be incorporated in the main distribution board. We recommend that an RCD (Residual Current Device) is used with all electrical products. It is particularly important to use an RCD with portable products that are plugged into a supply not protected by an RCCB. If in doubt consult a qualified electrician. You may obtain an RCD by contacting your local Sealey dealer. Electrical safety information, it is important that the following information is read and understood.

The Electricity at Work Act 1989 requires that all portable electrical appliances, if used on business premises, are tested by a qualified electrician, using a Portable Appliance Tester (PAT), at least once a year.

The Health & Safety at Work Act 1974 makes owners of electrical appliances responsible for the safe condition of those appliances and the safety of the appliance operators. If in any doubt about electrical safety, contact a qualified electrician.

Ensure that the insulation on all cables and on the appliance is safe before connecting it to the power supply. See 1.1.1. and use a Portable Appliance Tester.

Ensure that cables are always protected against short circuit and overload.

regularly inspect power supply cables and plugs for wear or damage and check all connections to ensure that they are secure.

Important: Ensure that the voltage rating on the appliance suits the power supply to be used and that the plug is fitted with the correct fuse - see fuse rating in these instructions.

DO NOT pull or carry the appliance by the power cable.

DO NOT pull the plug from the socket by the cable. Remove the plug from the socket by maintaining a firm grip on the plug.

DO NOT use worn or damaged cables, plugs or connectors. Ensure that any faulty item is repaired or replaced immediately by a qualified electrician.

1.2. This product is fitted with a BS1363/A 13 Amp 3 pin plug.

If the cable or plug is damaged, remove from use and ensure that repairs are carried out by a qualified electrician.

Replace a damaged plug with a BS1363/A 13A 3 pin plug. If in doubt contact a qualified electrician.

A) Connect the GREEN/YELLOW earth wire to the earth terminal 'E'.

B) Connect the BROWN live wire to the live terminal 'L'.

C) Connect the BLUE neutral wire to the neutral terminal 'N'.

D) After wiring, check that there are no bare wires and ensure that wires have

been correctly connected. Ensure that the cable outer sheath extends beyond the cable restraint and that the restraint is tight. Double insulated products are marked with the Class II symbol. Class II products are wired with live (brown) and neutral (blue) only. To rewire, connect the wires as indicated in diagram.

DO NOT connect either wire to the earth terminal.

Products which require more than 13 amps are supplied without a plug. Contact a qualified electrician to ensure that a suitably rated supply is available. Ensure that an industrial round pin plug and socket are fitted by a qualified electrician.

If an extension cable reel is used, ensure that it is fully unwound before connection. Use a reel that includes an RCD, an appliance will be protected by the RCD. The cable core section is important and should be at least 1.5mm². Ensure that the cable of the reel is appropriate for this product. We recommend the use of 2.5mm² core section cable.

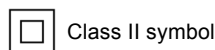

Class II symbol

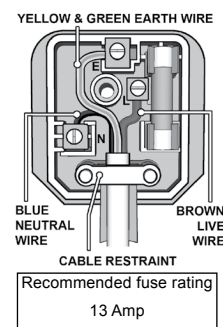

2. GENERAL SAFETY

- ✓ Check that the unit is in sound condition and good working order. *Take immediate action to repair or replace damaged parts.*
- ✓ Use recommended parts only. *Unauthorised parts may be dangerous and will invalidate the warranty.*
- ✗ **DO NOT** stand or place **any** object closer than 500mm from the unit.
- ✗ **DO NOT** obstruct the air intakes or outlets of the unit, and do not cover with washed clothes.
- ✗ **DO NOT** place any object into the outlets - the unit has a fan running at high speed, contact with this will cause injury.
- ✗ **DO NOT** operate the unit when you are tired or under the influence of alcohol, drugs or intoxicating medication.
- ✗ **DO NOT** switch the unit off by disconnecting it from the mains. **ALWAYS** switch to the "OFF" position first.
- ✗ **DO NOT** remove the float lever from the water collection tank.
- ✗ **DO NOT connect or disconnect the plug from the mains with wet hands.**
- ✓ Always discard the water from the collection tank, **DO NOT** use it for any other purpose.
- ✓ Place the unit on a level and stable surface.
- ✓ To prevent water from freezing, do not use the unit at ambient temperatures below 0°C.
- ✗ **DO NOT** use the unit outside.
- ✓ Ensure that heating appliances are not exposed to the flow of air from the unit.

- ✓ Before attempting to move the unit, empty the contents of the water tank. Use side carrying handles when moving unit.
 - ✓ Switch off and disconnect unit from the mains before attempting any cleaning or other maintenance work.
 - ✓ Ensure that the unit is turned off correctly when not in use, and stored in a safe, dry area, out of reach of children.
- NOTE:** This appliance can be used by children aged from 8 years and above and persons with reduced physical, sensory or mental capabilities or lack of experience and knowledge if they have been given supervision or instruction concerning use of the appliance in a safe way and understand the hazards involved. Children shall not play with the appliance. Cleaning and user maintenance shall not be made by children without supervision.

3. INTRODUCTION & SPECIFICATION

Thermostatically controlled unit with extendible exhaust hose and window kit - ideal for home or office environments. Features two-speed fan and electronic remote control. Air conditioning temperature range 17-30°C. Also features a dehumidifying function capable of removing up to 24ltr/day. Refrigerant is R410A. Mounted on castors for manoeuvrability. Cable storage keeps unit tidy when not in use.

Model No.: SAC9001
 Cooling Capacity: 9000Btu/hr
 Supply 230V
 Power 1000W
 Maximum Air Flow: 380mtr³/hr
 Maximum Water Extraction Rate: 24ltr/day
 Refrigerant R410A
 Discharge Side Pressure 3.6MPa
 Suction Side Pressure 1.2MPa
 Exhaust Hose Length. 1500mm
 Energy Class A
 Weight 22kg

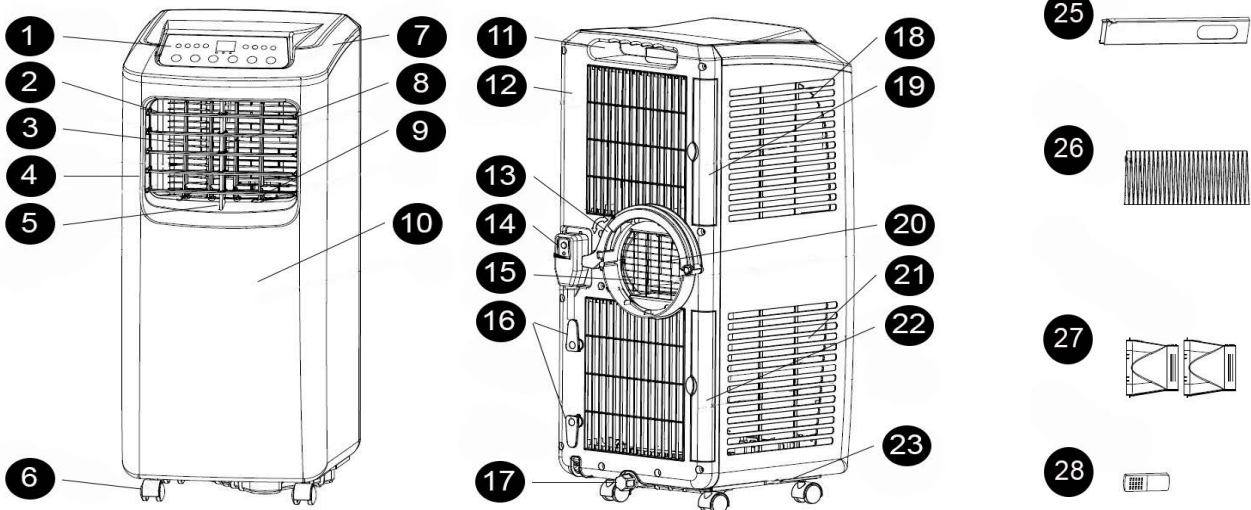

- | | |
|--|--|
| <ul style="list-style-type: none"> 1. Control panel. 2. Horizontal louvre. 3. Vertical louvre. 4. Air outlet frame. 5. Vertical Louvre connecting lever. 6. Caster. 7. Top cap. 8. Horizontal louvre connecting lever. 9. Main vertical louvre. 10. Front shell. 11. Handle / Remote Control Storage. 12. Back shell. 13. Retaining clamp. 14. Power cord. | <ul style="list-style-type: none"> 15. Air duct. 16. Wire-winding posts. 17. Drain cap. 18. Evaporator filter mesh. 19. Evaporator filter frame. 20. Radiating fine mesh. 21. Condenser filter mesh. 22. Condenser filter frame. 23. Base plate. 24. Window sealing board assembly. 25. Window sealing board. 26. Exhaust Hose. 27. Connector. 28. Remote control. |
|--|--|

4. INSTALLATION

- ❑ **WARNING:** leave this mobile air-conditioner in an upright position for at least 2 hours before first use. Ensure that the air-conditioner remains in an upright position whilst it is being moved. Place the air-conditioner on a flat ground surface.

4.1. Connector 25 and Window Sealing Board Assembly 28 are fitted to Exhaust Hose 26. Place 25 and 26 at each end of the hose and screw clockwise onto the hose to connect.

Exhaust hose Retaining Clamp assembly;

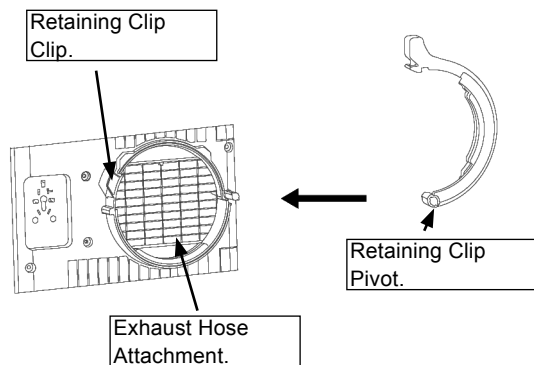

- 4.2. Select the exhaust hose retaining clamp.
- 4.3. Fit the exhaust hose to the circular aperture at the rear and secure with the retaining clamp. Rotate the retaining clamp anti-clockwise and snap the retaining clamp closed to secure the Heat Exhaust Hose.
- 4.4. Fit 27 window sealing board to the window as shown in Fig 1 (vertical) or Fig 2 (horizontal).
- 4.5. Installation of the unit

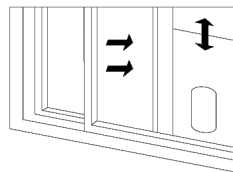

Fig 1

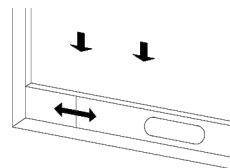
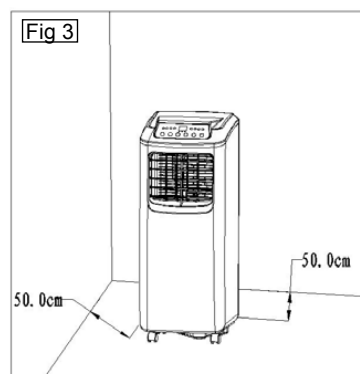

Fig 2

- 4.6. Position the mobile air-conditioner, with the exhaust hose assembly attached, near to a window. Keep the mobile air-conditioner at least 50cm away from the walls or other objects. (As shown in Fig 3).



- 4.7. Snap the flat end of the exhaust hose connector into the elliptical hole of the window sealing board assembly (as shown in Fig 4 and Fig 5).
- 4.8. To ensure adequate operation, ensure that the exhaust hose is not kinked. And do not bend the exhaust hose any more than 45°.

❑ Important:

The exhaust hose is 280mm-1500mm long and this length is determined based on the specification of the air-conditioner (s). Do not use hoses with other specifications. Do not replace with non-genuine components as this may affect the functions of the air-conditioner. The flow of exhaust must be smooth. Obstructed exhaust may cause the air-conditioner to overheat.

5. OPERATION

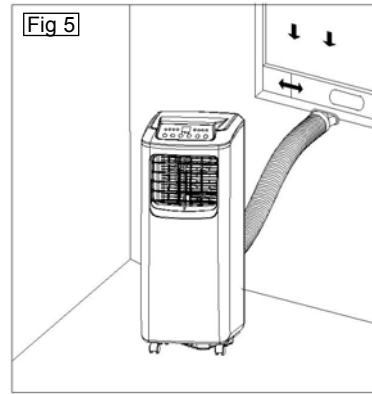
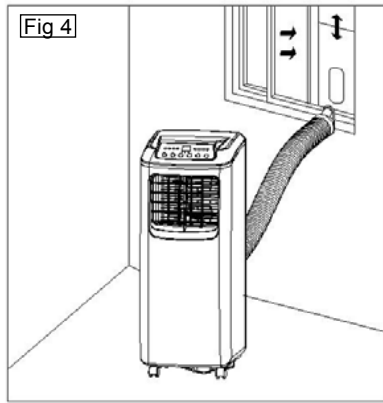

Control Setting

5.1. Select the operation interface depending on the models and functions. The operation interfaces is as follows:

Functions Setting

5.2. This portable air conditioner has three functions: cooling, dehumidifying and fan. The fan has two speeds: high speed and low speed, setting temperatures range between 17°C and 30°C (62 and 86°F), 24 hours timer, water-level protective function.

Control keys:

POWER Key: Press the key to start the unit, press this key again to turn unit off.

Mode Key: Set the Cooling, Dehumidifying and Fan Mode.

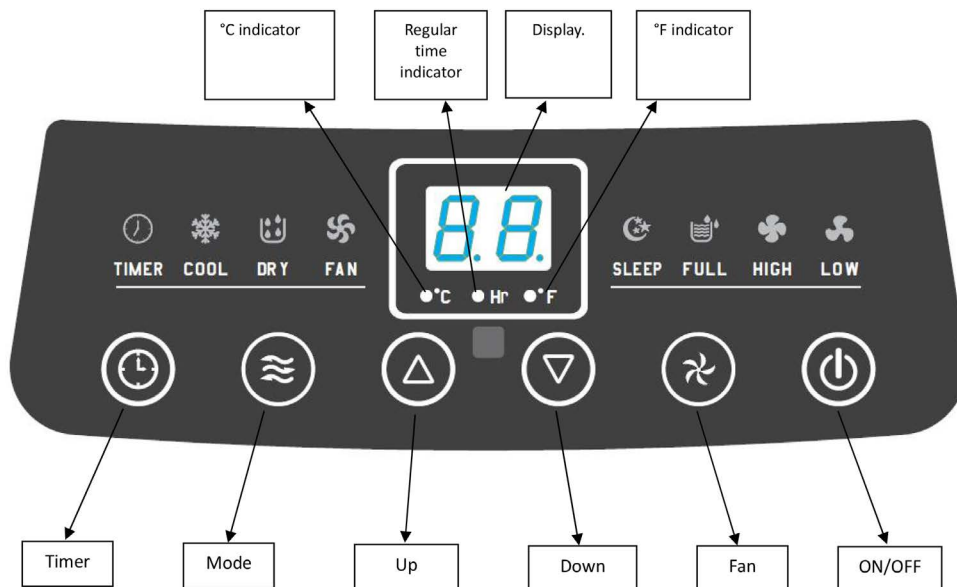

Fan Speed: Pressing the button, fan speed change by low - high - low loop manner, but not available in dehumidifying mode.

Timer Key: When setting the time, the Regular time indicator will illuminate.

Up/Down Key: Press these keys to set the desired room temperature and time.

Switch between °C and °F by pressing these two keys simultaneously or by using the Remote Control.

Operation instructions:

5.3. In Cooling mode;

5.4. $T_a \geq T_s + 1^\circ\text{C}$ (1°F), the cooling starting.

5.5. $T_a \leq T_s - 1^\circ\text{C}$ (1°F), the compressor stops and only the fan motor remains working at the set fan speed.

5.6. T_a : Room Surrounding Temperature

5.7. T_s : Setting Temperature

5.8. In this mode, press Timer and Down button to set sleep function, In sleep function, after operating two hours, the set temperature increases 1°C (1°F) automatically.

5.9. After operating for another 2 hours, the set temperature will increase 1°C (1°F) again. Then the set temperature will not change and the fan will switch to low level.

5.10. In dry mode, if the ambient temperature $\geq 17^\circ\text{C}$ (62°F), the compressor will start. Then, the unit is controlled in the following manner: when the ambient temperature $\leq 15^\circ\text{C}$ (59°F), the compressor shuts down. When the ambient temperature rises to be $\geq 17^\circ\text{C}$ (62°F), the compressor starts again. The start/stop of the compressor meets the requirement for 3-minute protection time.

5.11. In fan mode, fans runs on both high speed or low speed. Temperature setting displays environment temperature between 10 / 35°C (50 / 95°F).

5.12. Timer setting.

A) Upon start, press the Timer button to enter timed shutdown. Upon shutdown, press this button to enter timed start. In the meanwhile, the timer indicator will illuminate.

B) Press the Timer button to enter the timing function (timed start/timed shutdown). Adjust the up or down button to set the timing time.

The time will cycle in the order of

1-2-3-.....24 0 - 1 hours or

24-23-22-.....1 0 - 24 hours.

The timing function adjustment is relative to time.

C) After timed start is set, once the timed start time is reached, the unit will start.

In the meantime, the timer indicator will extinguish and the ambient temperature is displayed.

D) After timed shutdown is set, when the shutdown time is reached the unit will shut down.

In the meanwhile, the timer indicator will extinguish and the ambient temperature is displayed.

E) Only the final setting of the timing function is activated. This setting is for one operation.

F) ON/OFF operations on the Control Panel or Remote Control will clear all timing settings.

G) Once the timing is determined, if the timer button is pressed once, it is possible to query the remaining timed start/shutdown time. If the timer button is pressed twice continuously within 5s, the timing will be cancelled.



Use the up button and down button to change the temperature set value.

Remote control operating instructions

The operation instructions of the buttons of this simple remote control are as follows:

Power button: press this button to turn on/off the unit;

Timer button: upon shutdown, press this button to set timed start; upon start, press this button to set timed shutdown.

High button: press this button to allow the unit to operate in the high fan speed state (except in the dry and sleep modes);

Low button: press this button to allow this unit to operate in the low fan speed state;

Up button: press this button to increase the temperature and timing value;

Down button: press this button to decrease the temperature and timing value;

°C — F button: press this button to switch between the Celsius degree and Fahrenheit degree;

Cool button: press this button to set this unit to operate in the cooling mode;

Fan button: press this button to set this unit to operate in the air supply mode;

Dry button: press this button to set this unit to operate in the dry mode;

Sleep mode: press this button to set this unit to operate in the sleep mode.

Multiple protection functions:

Anti-freeze protection function:

Upon cooling, when the compressors operates continuously for more than 10 minutes, if the pipe temperature T_p is less than or equal to 2°C continuously for 20 seconds, the compressor and water spraying motor turn off, other loads operate and LED displays E4, the unit initiates the anti-frost protection function and the buttons are inactive (except the OFF button). Once the pipe temperature rises to exceed or equal 8°C, the protection is relieved, the original status is restored and the unit meets the requirements for 3-minute delay protection of the compressor.

Full water protection function:

When the water in the water tray exceeds the alarm level, the unit will alarm automatically and the full water indicator illuminates. In this case, you need to drain the condensate in the unit; otherwise, the unit will shut down automatically after the buzzer gives off 5 beeps.

(For more information about the drain method, refer to the "Drain"). If the unit is not shut down manually, the unit will be restored to the previous operating status automatically once the water is fully drained. Or the power may be turned on again to start the unit.

Delay protection function of the compressor:

This unit offers restart protection for the compressor. Except that the compressor may start immediately when the unit is energized for the first time, there is 3-minute delay start protection after the compressor is shut down.

6. WATER DRAINAGE

6.1. Manual drain (Fig 6)

The unit will shut down when the water level is full.

Turn off the power and unplug the power cable.

Note: move the unit carefully to avoid spillage of water in the water tray at the bottom of the unit.

Place a vessel beneath the water outlet, at the back of the unit, to drain water.

Unscrew the drain cap and remove the water plug to allow water to flow into the vessel.

Note:

Protect the drain cap and water plug from becoming detached.

Tilt the unit slightly backward when draining.

Fig 6

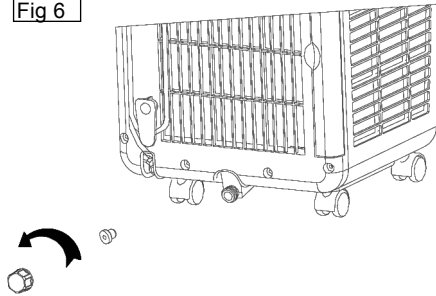

6.2. Continuous drain:

1). Unscrew the water cap in the direction shown by the arrow and unplug the water plug;(Fig 7)

2). Attach a drain hose onto the water outlet; (Fig 8)

3). Connect the drain hose to a suitable drainage point.

Note:

The drain hose must be installed when there is no water in the baseplate;

When operating in the cooling mode, to ensure the water for radiation of the condenser of the unit and to enhance the cooling effects of the unit, it is recommended that continuous drain is not be set when the unit is in use;

When operating in the heating mode, use continuous drain; otherwise, the unit may shut down due to water level becoming full;

Place the drain hose at a height that is not above the water outlet.

Prevent the drain hose from becoming kinked.

When continuous drain is in use, keep the drain cap and water plug closed.

Fig 7

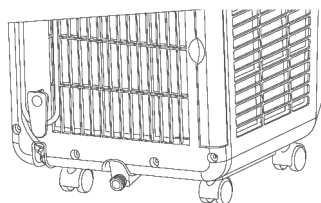
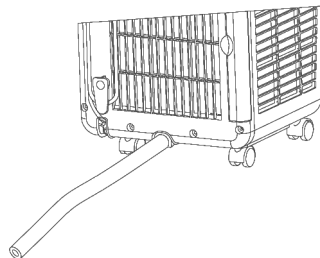

Fig 8



7. MAINTENANCE & SERVICING

Prior to maintenance and servicing of the unit, turn off and unplug the unit.

7.1. Surface cleaning

Clean the surface of the unit with wet soft cloth.

Do not use chemical solvents as these may damage the unit.

7.2. Filter Frame and Filter Mesh cleaning

Clean the filter mesh once every two weeks.

If the filter frame and filter mesh are clogged with dust, the function of the air-conditioner may Decrease

Remove the evaporator filter frame and the condenser filter frame gently in the direction shown by The arrow (as shown in Fig 9).

Remove the evaporator filter mesh and condenser filter mesh gently in the direction shown by the Arrow (as shown in Fig 10).

Remove the filter frame first and then take out the filter mesh.

Note: when taking out the filter frame or filter mesh, the force shall be applied evenly to avoid twisting or damage of the filter frame or filter mesh.

Place the evaporator filter frame, condenser filter frame, evaporator filter mesh, and condenser filter mesh into warm water (about 40°C).

Fig 9

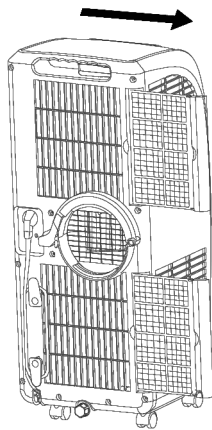
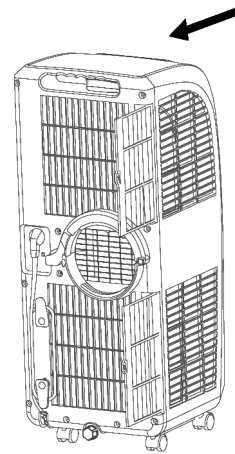

Fig 10



Use neutral cleaner. Dry in the shade. (Fig 11)

Note: 1. Do not damage the mesh fabric on the filter frame and filter mesh.

7.3. Installation of the filter frame and filter mesh

Install the filter mesh first and then install the filter frame.

7.4. To install the evaporator filter mesh and condenser filter mesh, point the back end of the filter mesh toward the socket and then push the filter mesh evenly and gently into the socket.

Note: Install the filter mesh in the reverse order of removal. The filter mesh must be installed into place; otherwise, the filter frame may not be installed into place.

Fig 11

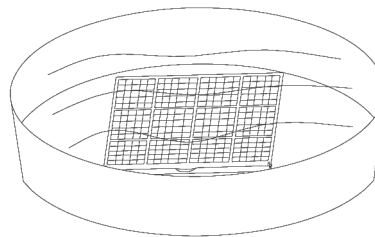

7.5. Install the filter mesh gently so as not to damage it.

To install the evaporator filter frame and condenser filter frame, point the back end of the filter frame toward the socket and then push the filter frame evenly and gently into the socket.

Note: 1. Install the filter frame in the reverse order of removal. Be sure to install the filter mesh first before the filter frame is installed. Install the filter frame gently so as not to damage it

7.6. Cleaning of the handle position and remote control storage area

Remove the remote control from the storage area (Fig 12). Clean the handle position and remote control storage area with damp soft cloth only. **DO NOT** allow water to drip into the unit. **DO NOT** soak the cleaning cloth.

Fig 12

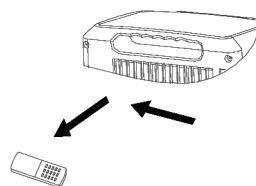

8. HANDLING AND MOVING THE UNIT

To handle or move the unit, hold the top of the air outlet on the front of the unit with one hand and the handle position at the top of the back of the unit with another hand. Ensure that the unit remains upright

Do not hold the horizontal louvre by hand.

Leave the unit in the upright position when handling or moving it.

To handle or move the unit, drain the water in the unit first to prevent the water in the unit from flowing onto the ground or carpet.

If the remote control is in the position of the handle, take out the remote control.

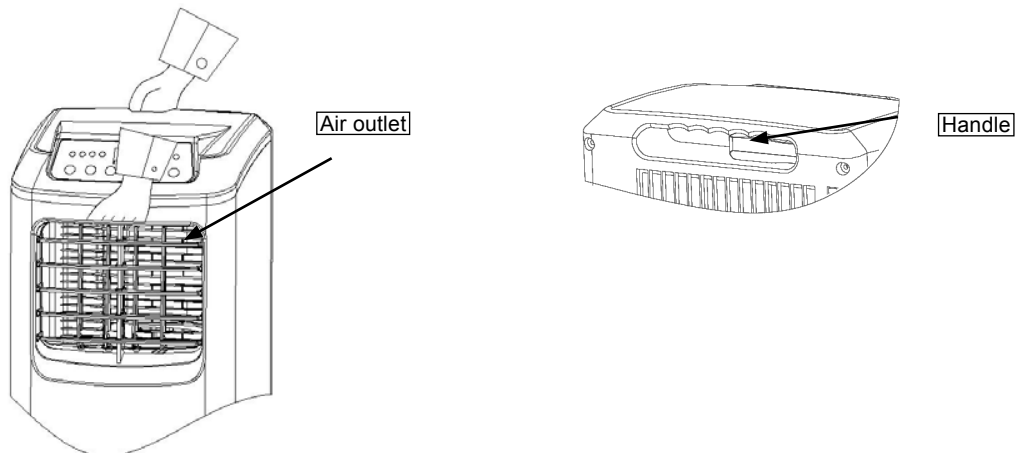

End of Season Storage.

8.1. Unscrew the drain cap, unplug the water plug and drain the water in the water tray to a suitable vessel.

Note: **DO NOT** tilt the unit any further than 30° from vertical.

8.2. Start the unit, adjust mode to the low fan speed setting, keep the unit in this state for half a day in order to dry the interior of the unit to prevent mold.

8.3. Turn off the unit, unplug the power plug, wrap the power cord around the wire-winding post, insert the plug into the storage point on the rear of the unit; install the water plug and drain cap.

8.4. Remove the exhaust hose assembly and store appropriately to prevent damage.

Note: to remove the exhaust hose assembly, hold the handle of the exhaust hose retaining clamp, pull the retaining clamp outward evenly, rotate the retaining clamp clockwise to open. Remove the exhaust hose assembly.

8.5. Pack the air-conditioner properly with soft plastic bag. Store the unit in a dry and dust proof place. Keep the unit out of the reach of children.

8.6. Remove batteries from the remote control. Store remote control in an appropriate place.

8.7. Ensure that the unit is stored in a dry place.

9. TROUBLE SHOOTING

Never repair or remove the air-conditioner yourself. Repair conducted by unqualified persons will void the warranty card and may cause harm to the persons and property.



Problem/fault indication	Cause	Remedy
The air-conditioner does not work	No power	Connect the unit to a live socket and turn it on.
	Full water indicator illuminates?	Drain the water stored in the unit.
	Ambient temperature too low ?	It is recommended that this unit be operated at 10-35°C.
	The room temperature is lower than the set temperature in the cooling mode.	Change the set temperature
Bad cooling or heating effects	Direct sunlight	Draw curtain.
	The doors and windows are open, the room is crowded or there are other heat sources near the cooling mode	Close doors and windows. Add new air-conditioners
	Filter mesh very dirty	Clean or replace the filter mesh
	Air inlet or air outlet obstructed	Remove the obstruction
Excessive noise	Air-conditioner not on a flat surface	Place the air-conditioner in a flat and firm place.
The compressor does not work	Overheat protection activated.	Wait 3 minutes until the temperature decreases and then turn the unit on.
The remote control does not work	Too long a distance	Move the remote control closer to the air-conditioner. Ensure that the remote control points toward the receiver.
	The remote control does not point toward the receiver	
	Batteries flat	Replace the batteries
Display E1	Pipe temperature sensor failure	Check the pipe temperature sensor and related circuits
Display E2	Room temperature sensor failure	Check the room temperature sensor and related circuits
Display E4	Anti-freeze protection	Functions are restored when unit returned to operating temperature.
Full water indicator illuminates	The water in the baseplate of the unit reaches the full water level	Drain the water in the baseplate.

NOTE: It is our policy to continually improve products and as such we reserve the right to alter data, specifications and component parts without prior notice.

IMPORTANT: No liability is accepted for incorrect use of this product.

WARRANTY: Guarantee is 12 months from purchase date, proof of which will be required for any claim.



Environmental Protection

Recycle unwanted materials instead of disposing of them as waste. All tools, accessories and packaging should be sorted, taken to a recycling centre and disposed of in a manner which is compatible with the environment.



WEEE Regulations

Dispose of this product at the end of its working life in compliance with the EU Directive on Waste Electrical and Electronic Equipment (WEEE). When the product is no longer required, it must be disposed of in an environmentally protective way. Contact your local solid waste authority for recycling information.



Battery Regulations

Under the Waste Batteries and Accumulators Regulations 2009, Jack Sealey Ltd are required to inform potential purchasers of products containing batteries (as defined within these regulations), that they are registered with Valpak's registered compliance scheme. Jack Sealey Ltd's Batteries Producer Registration Number (BPRN) is BPRN00705.



Sole UK Distributor, Sealey Group,
Kempson Way, Suffolk Business
Park, Bury St. Edmunds, Suffolk,
IP32 7AR



01284 757500



www.sealey.co.uk



01284 703534



sales@sealey.co.uk